



# EASTERN MEDITERRANEAN UNIVERSITY

ENTRANCE AND SCHOLARSHIP EXAM, 2024

02.06.2024

## QUESTION BOOKLET

### GENERAL DESCRIPTION

1. A question booklet and an answer sheet have been distributed to you for this exam. The question booklet consists of 26 pages. Please check.
2. Your name, surname, exam center, exam hall and candidate number are written and coded by the computer on the answer sheet. Check the information on the answer sheet.
3. Code the booklet type on the answer sheet.
4. The duration of the exam is 150 minutes.
5. Five different answer options were given to each questions in the tests. Only one of these options is correct.
6. After carefully examining the question and the options given, shade the most appropriate option with a dark black pencil. Don't use pen, use pencil.
7. Since there is one correct answer for each question, cross out only one place. A question with more than one answer marked will be considered incorrectly answered. If you want to change the answer you marked, erase the inside of the circle thoroughly with a soft eraser.
8. Don't mark the answer you are not sure about. For each incorrectly marked answer in this exam, one fourth of the point value corresponding to a correct answer will be deducted.
9. You can use appropriate spaces in the question booklet for scribbling purposes.
10. Don't fold your answer sheet, don't crumple it or make any unnecessary marks on it.
11. For questions you can not answer, move on the other questions without wasting too much time. If you have time at the end, you can check these questions again.

**GOOD LUCK**

Candidate's name, surname	
Candidate number	



The Question Booklet consists of 5 tests, each consisting of 30 questions.

The page numbers of the tests are as follows:

- Mathematics – 2 Test            1 – 6
- Science Test                        7 – 20
- English Language Test            21 – 26

## MATHEMATICS – 2 TEST

1. If  $a = -\frac{5}{3}$  and  $b = 2$ , determine the value of

$$27a^3 + 27a^2b + 9ab^2 + b^3$$

A)  $-125$

B)  $-27$

C)  $-8$

D)  $27$

E)  $125$

2. If  $a + b = 6$   
 $b + c = 8$

Determine the value of

$$\frac{b^2 + ab + ac + bc}{c^2 - ab + bc - ac}$$

A)  $7$

B)  $6$

C)  $5$

D)  $4$

E)  $3$

3. If  $k - t = 6$   
 $m - t = 8$

Determine the value of

$$k^2 - 2km + m^2$$

A)  $4$

B)  $6$

C)  $8$

D)  $10$

E)  $14$

4. Which of the following is a factor of

$$(a - b)(a - c)^2 + (b - a)^2(c - a)$$

A)  $a + b$

B)  $a + c$

C)  $a + b - c$

D)  $b + c$

E)  $c - b$

5. Which of the following is the factorized form of

$$m^2n + mn^2 + mn + n^2$$

A)  $mn(m + n)$

B)  $m(m + n)(m + 1)$

C)  $m(m + n)(n + 1)$

D)  $(m + n)(n + 1)$

E)  $n(m + 1)(m + n)$

6. What is the sum of the integers whose square minus 63 is less than its twice?

A)  $15$

B)  $23$

C)  $24$

D)  $28$

E)  $36$

## MATHEMATICS – 2 TEST

7. Determine the sum of the roots of the following equation.

$$(x^2 - x)^2 - 9(x^2 - x) + 20 = 0$$

- A)  $-\frac{7}{2}$   
B)  $-1$   
C)  $0$   
D)  $2$   
E)  $\frac{9}{2}$

8. Given  $\frac{3}{x} - \frac{m}{3}x = x + 1$ .

If the sum of the roots of the equation given above is  $\frac{1}{2}$ , determine the value of  $m$ .

- A)  $-10$   
B)  $-9$   
C)  $1$   
D)  $3$   
E)  $6$

9. Given  $P(x) = (2x + 1)(4x^2 - 2x + 1)$

Determine  $P(\sqrt[3]{3})$ .

- A)  $25$   
B)  $23$   
C)  $19$   
D)  $17$   
E)  $14$

10.  $P(x)$  and  $Q(x)$  functions are given below;

$$P(x) = 12 + x^2 - 5x^3$$

$$\text{and } Q(x^2) = x^2 - x^4$$

Which of the following is

$$P(x) - xQ(x).$$

- A)  $12 - 4x^3$   
B)  $12 - 6x^3$   
C)  $12 + 2x^2 - 6x^3$   
D)  $12 + 2x^2 - 4x^3$   
E)  $2x^2 - 4x^3$

11. The polynomial function;  $P(x)$ , satisfy

$$3P(x) + P(-x) = 4x^2 - 6x + 4.$$

Determine the value of  $P(1)$ .

- A)  $-3$   
B)  $-2$   
C)  $-1$   
D)  $1$   
E)  $3$

12. If  $a < 0$  and  $b < 0$ , then find the solution set of the inequality

$$\frac{x^2 - a^2}{bx - ab} \geq 0$$

- A)  $[-a, \infty)$   
B)  $[a, \infty)$   
C)  $[-a, a)$   
D)  $(-\infty, a) - \{-a\}$   
E)  $(-\infty, -a] - \{a\}$

## MATHEMATICS – 2 TEST

13. If  $\frac{1}{2}$  is a root of

$$x^2 - (2\cos a)x - \sin^2 a = 0,$$

where  $0 < a < \frac{\pi}{2}$

then determine the value of  $\cos a$

- A)  $\frac{3}{4}$   
 B)  $\frac{1}{2}$   
 C)  $-\frac{1}{2}$   
 D)  $-\frac{5}{8}$   
 E)  $-\frac{3}{4}$

14. Determine the value of  $\sec x$ , if  $\frac{\sin x - 2\cos x}{2\sin x + \cos x} = \frac{1}{3}$ , where  $0 < x < \frac{\pi}{2}$

- A)  $5\sqrt{2}$   
 B)  $\sqrt{5}$   
 C)  $\frac{2}{\sqrt{3}}$   
 D)  $2\sqrt{3}$   
 E) 7

15. Find the domain of the logarithmic function;

$$\log_{\sqrt{2}} \left( \frac{x^2 - 4x - 5}{1 - x^2} \right)$$

- A)  $(-5, \infty)$   
 B)  $(-1, 5)$   
 C)  $(1, 5)$   
 D)  $(-1, 5) - \{1\}$   
 E)  $(-1, 1)$

16.  $A$  and  $B$  are two events defined on a sample space.

Determine the conditional probability;  $P(B|A)$ , if  $P(A) = 0.45$ ,  $P(B) = 0.7$  and  $P(A \cup B) = 0.8$ .

- A)  $\frac{4}{9}$   
 B)  $\frac{5}{9}$   
 C)  $\frac{2}{3}$   
 D)  $\frac{7}{9}$   
 E)  $\frac{8}{9}$

17. 60% of the chocolates in a market are dark and the rest are milky. 20% of dark chocolates and 60% of milky chocolates contain hazelnuts and the rest contains pistachios.

If a chocolate randomly bought from the market contains pistachios, determine the probability that the chocolate is milky.

- A)  $\frac{4}{5}$   
 B)  $\frac{3}{4}$   
 C)  $\frac{1}{2}$   
 D)  $\frac{1}{4}$   
 E)  $\frac{1}{5}$

CANCELLED

## MATHEMATICS – 2 TEST

18. The line  $y = 4 - 2x$  is tangent to the curve  $y = f(x)$  at the point  $C$ .

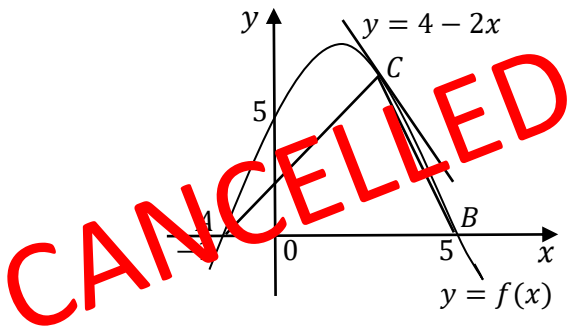

Determine the area of the triangle  $ABC$ .

- A) 18  
 B) 24  
 C) 28  
 D) 30  
 E) 36
19. The graph of the function;  $y = f(x)$  is given below.

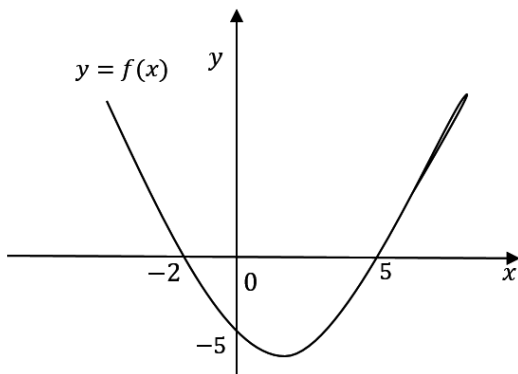

Determine the value of  $f(-1)$ .

- A) -4  
 B) -3  
 C)  $-\frac{3}{2}$   
 D) -1  
 E)  $-\frac{1}{2}$

20. Given  $f(x) = \frac{2}{x+2}$  and  $g(x) = \frac{x+1}{x-2}$

Determine  $(f \circ g)'(0)$ .

- A)  $-\frac{3}{2}$   
 B)  $-\frac{2}{3}$   
 C)  $\frac{2}{3}$   
 D)  $\frac{4}{3}$   
 E)  $\frac{3}{2}$

21. Determine  $f'(1)$ , if

$$f(x) = (x + 1)^3 (x^2 + 1)^2$$

- A) 100  
 B) 104  
 C) 108  
 D) 110  
 E) 112

22. Evaluate the following indefinite integral

$$\int (6x - 6)(x^2 - 2x - 3)^2 dx$$

- A)  $(x^2 - 2x - 3)^3 + C$   
 B)  $\frac{1}{3}(x^2 - 2x - 3)^3 + C$   
 C)  $\frac{1}{2}(x^2 - 2x - 3)^3 + C$   
 D)  $2(x^2 - 2x - 3)^3 + C$   
 E)  $3(x^2 - 2x - 3)^3 + C$

MATHEMATICS – 2 TEST

23. In the figure;  
 $l_1 \parallel l_2$ ,  $|AB| = |AC|$ ,  $m(\widehat{BAL_1}) = 110^\circ$ ,  
 and  $m(\widehat{BCL_2}) = 140^\circ$ .

Find  $m(\widehat{BAC}) = x$ .

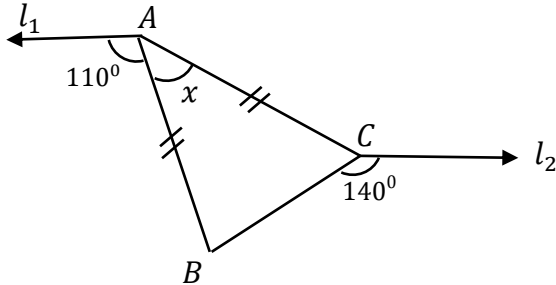

- A) 30
- B) 40**
- C) 45
- D) 50
- E) 60

24. In the figure;  
 $5x - 7y + 14 = 0$  is the equation of the line which passes through the points A and B. It is also given that the point C is  $C(\frac{16}{5}, 0)$ .

Find the area of the triangle;  $A(ABC)$ .

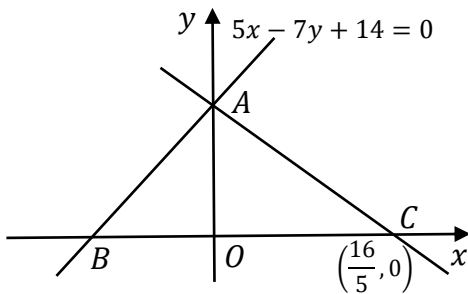

- A) 12
- B) 9
- C) 8
- D) 6**
- E) 5

25. In the figure;  $ABCD$  is a square and  
 $m(\widehat{BCE}) = 15^\circ$ .

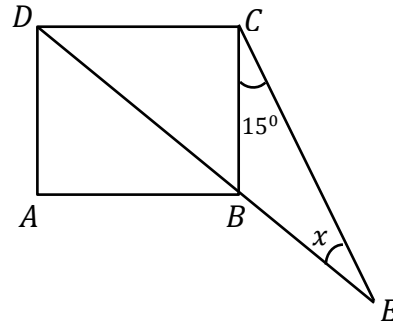

Find  $m(\widehat{BEC}) = x$ .

- A) 10
- B) 15
- C) 25
- D) 30**
- E) 45

26. In the figure,  $ABC$  and  $ABD$  are isosceles triangles,  $|AB| = |AC|$ ,  $|AD| = |BD|$  and  
 $m(\widehat{DAC}) = 45^\circ$ .

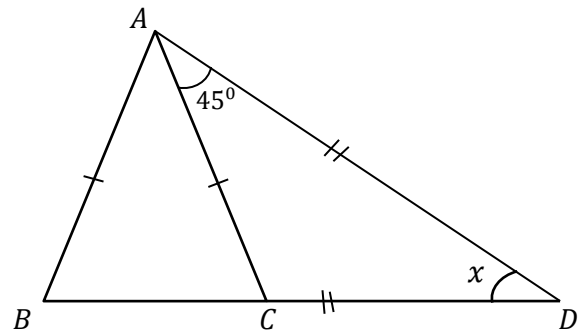

Find  $m(\widehat{DCA}) = x$ .

- A) 75
- B) 60
- C) 45
- D) 30**
- E) 25

## MATHEMATICS – 2 TEST

27. In the figure;  $ABCD$  is a square,  $[BF] \perp [AE]$ ,  $|BC| = 8 \text{ cm}$ , and  $|AE| = 10 \text{ cm}$ .

Find  $|BF| = x$

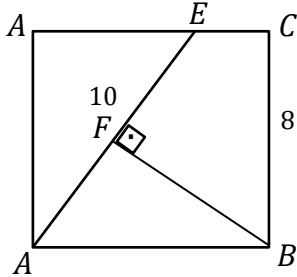

- A)  $\frac{16}{3}$
- B)  $\frac{18}{5}$
- C)  $\frac{32}{5}$
- D) 4
- E) 6

28. In the figure;  $OABC$  is a equilateral rectangle and the point  $B$  is  $B(16, 8)$ . Determine the slope of the equation of the line which passes through the points;  $A$  and  $C$

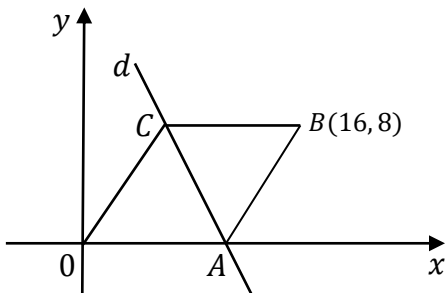

- A)  $-\frac{5}{3}$
- B)  $-\frac{4}{3}$
- C)  $-\frac{3}{2}$
- D)  $-3$
- E)  $-2$

29. In the figure;  $ABC$  is a triangle,  $BC \parallel DE$ ,  $FE \parallel AC$ ,  $|BF| = |FC| = 3 \text{ cm}$ ,  $|DE| = 5 \text{ cm}$ .

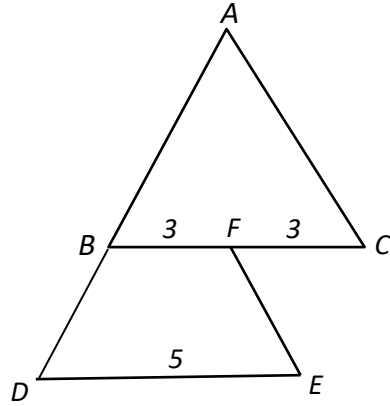

Determine the ratio;  $\frac{|AB|}{|BD|}$

- A) 2
  - B) 3
  - C) 4
  - D) 5
  - E) 6
30. In the figure;  $ABC$  is a right triangle,  $|AB| \perp |AC|$ ,  $|AH| \perp |BC|$ ,  $|AH| > |BH|$ ,  $|BH| = 2 \text{ cm}$ ,  $m(\widehat{ABC}) = \alpha$  and  $\sin 2\alpha = \frac{4}{5} \text{ tir}$ .
- Determine the area of the triangle  $ABC$ , in  $\text{cm}^2$ .

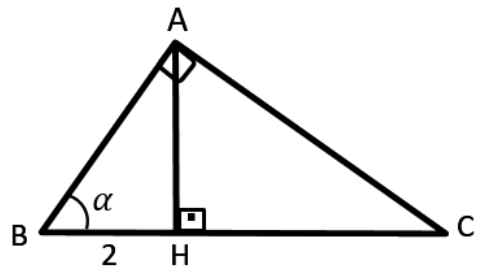

- A) 30
- B) 25
- C) 20
- D) 15
- E) 10

Mathematics – 2 Test ended.



## SCIENCE TEST

### BIOLOGY QUESTIONS

1. Hormones in human body;
- They are regulatory molecules.
  - They are carried to target organs by blood.
  - If they are secreted too little or too much, they cause some diseases to occur.

Which of these statements are correct?

- A) Only I.  
B) Only III.  
C) I. and III.  
D) II. and III.  
E) I., II. and III.

2. Occurs in living things,
- photosynthesis,
  - respiratory,
  - fermentation,
  - glycogen synthesis,

Which reactions are assimilations and which are recombination?

- | <u>assimilation</u> | <u>recombination</u> |
|---------------------|----------------------|
| A) I., II.          | III., IV.            |
| B) I., IV.          | II., III.            |
| C) III., IV.        | I., II.              |
| D) II., III.        | I., IV.              |
| E) I., II., IV.     | II.                  |

3. Cells formed as a result of mitosis,
- number of gene types
  - number of chromosome
  - number of organelles

Which of the quantities are different from the parent cell?

- A) Only I.  
B) Only II.  
C) Only III.  
D) I. and II.  
E) II. and III.

4. I. Temperature of the environment,  
II. The size of the molecule to be transported,  
III. Concentration difference between the two environments,

Depending on, which of the above factors diffusion speed may vary?

- A) Only I.  
B) Only II.  
C) I. and II.  
D) I. and III.  
E) I., II. and III.

## SCIENCE TEST

5. A person's metabolic speed,
- age,
  - gender,
  - physical activity,
  - environment temperature,
- Which of the above factors affect a person's metabolic speed?
- II. and IV.
  - I., II. and III.
  - I., III. and IV.
  - II., III. and IV.
  - I., II., III. and IV.**
6. A woman with blood type O has a child with blood type O.
- A0
  - B0
  - AB
- Which of the above genotypes, the father of the child can not have?
- Only I.
  - Only II.
  - Only III.**
  - I. and II.
  - II. and III.
7. Which of the following is the responsible organelle for protein synthesis?
- Chloroplast
  - Ribosome**
  - Endoplasmic Reticulum
  - Golgi Body
  - Centrosome
8. In humans, there are types of muscles such as;
- striated muscle,
  - heart muscle,
  - smooth muscle.
- Which of these muscles cause involuntary and rapid contractions?
- Only I.
  - Only II.**
  - I. and II.
  - I. and III.
  - II. and III.
9. Which of the following is not a function of the skeletal system in humans?
- Taking part in the production of blood cells
  - Facilitating movement with striated muscles
  - Creating an attachment surface to muscles
  - Protection of internal organs
  - Serve the potassium and sodium needs of the body**
10. Which of the following is false for a dominant species in a terrestrial ecosystem?
- It forms the top step of the food pyramid**
  - It has adapted very well to its environment
  - It consists of the most common individuals in the ecosystem
  - It can benefit from light energy
  - It is the species with high biomass

## SCIENCE TEST

### CHEMISTRY QUESTIONS

11. The total number of electrons in the

$XO_4^{-1}$  ion is 58. Regarding  ${}^m_5X$ ;

I.  $m$  is 25.

II. Number of neutrons is 31.

III. The oxidation level of  $X$  in the ion

$XO_4^{-1}$  is +6.

Which of these statements are correct?

(80)

A) Only I.

B) I. and II.

C) I. and III.

D) II. and III.

E) I., II. and III.

12. Which of the following statements about atoms is incorrect?

A) Protons, neutrons and electrons are in the nucleus of the atom.

B) The mass number is equal to the sum of the number of protons and neutrons in the nucleus.

C) If a neutral atom gains an electron, it acquires a (-) charge.

D) When a neutral atom loses or gains electrons, its chemical properties change.

E) If a neutral atom loses electrons, it becomes (+) charges.

13. Which of the following about  ${}^{29}_{14}Si$  atom is incorrect?

A) The nucleus core is 14.

B) Its atomic number is 14.

C) The number of neutrons is 15.

D) The number of electrons in neutral state is 14.

E) In neutral state, the number of electrons is greater than the number of neutrons.

14. By looking the simple formula of a compound;

I. Type of the elements forming the compound

II. Mole ratio of the elements forming the compound

III. The mass of 1 mole of the compound

Which of the quantities given above can be found?

A) I. and II.

B) II. and III.

C) I., II. and III.

D) Only I.

E) Only II.

## SCIENCE TEST

15. The masses of 0.01 moles of each compounds;  $XY_2$  and  $X_2Y_3$  consisting of the elements  $X$  and  $Y$  are 0.87 and 1.58 grams, respectively.

Accordingly, what are the atomic masses of  $X$  and  $Y$ ?

$X$	$Y$
-----	-----

- |       |    |
|-------|----|
| A) 52 | 16 |
| B) 55 | 32 |
| C) 55 | 16 |
| D) 56 | 32 |
| E) 56 | 31 |
16. The weight of 5 moles of the mixture consisting of  $CH_4$  and  $C_2H_4$  gases is 116 grams. Accordingly, determine, how many moles of  $CH_4$  are there in the mixture? ( $H: 1, C: 12$ )
- A) 1  
B) 1.5  
C) 2  
D) 3  
E) 4

17. If 200 grams of water is added to 300 grams of salt solution of 60% by mass. What percentage by mass will be the resulting solution?
- A) 18  
B) 24  
C) 30  
D) 36  
E) 72

18. When  $Y$  is added little by little to a certain amount of  $X$ , the reaction  $2X + 3Y \rightarrow X_2Y_3$  occurs. The graph regarding the reaction is given below.

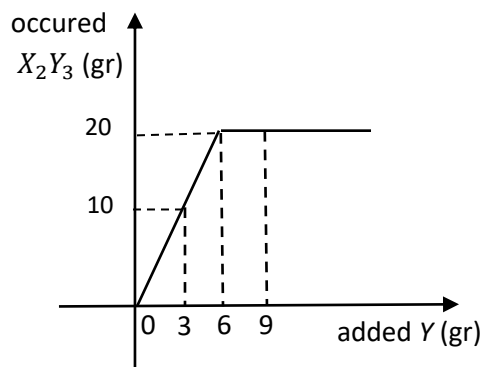

Accordingly, which of the following is incorrect?

- A) When all of  $X$  is finished, the amount of  $Y$  spent is 6 grams.  
B) When 9 grams of  $Y$  are added, 3 grams remain.  
C) Maximum 20 grams of  $X_2Y_3$  are formed.  
D) In the compound  $X_2Y_3$  the mass ratio of  $X/Y$  is  $7/6$ .  
E) At the beginning, there are 14 grams of  $X$ .
19. When equal volumes of  $NH_3$  and  $Cl_2$  gases are reacted to form  $N_2$  and  $HCl$  gases, the total volume increases by 4 liters, in the same conditions. Accordingly, what is the initial volume of the mixture in liters?
- A) 6  
B) 12  
C) 15  
D) 18  
E) 24

## SCIENCE TEST

20. The tap between the containers in the figure is opened at a constant temperature, allowing the gases to mix.

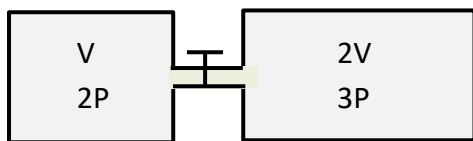

Accordingly, what will be the final pressure, in P?

- A)  $\frac{3}{5}$
- B)  $\frac{8}{3}$
- C) 2
- D) 3
- E) 4

### PHYSICS QUESTIONS

21. An object with a mass of 0.2 kg, standing on a frictionless horizontal surface, is moved 4 m, under the effect of a horizontal force of 40 N, as shown in the figure.

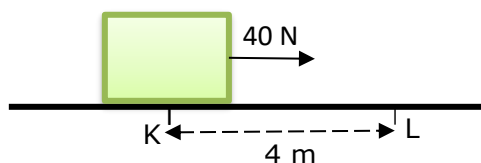

Accordingly, what is the velocity of the object, in m/s at the end of this path?

- A) 16
- B) 32
- C) 36
- D) 40
- E) 60

22. The masses, initial and final temperatures of the ice pieces; K, L and M are given in the following table.

ice pieces	Mass (gr)	Initial temperature ( $^{\circ}\text{C}$ )	Final temperature ( $^{\circ}\text{C}$ )
K	150	-30	-20
L	150	-30	-10
M	200	-30	-10

The heat received by these ice pieces for this temperature change is;  $Q_K$ ,  $Q_L$  and  $Q_M$ , respectively.

What is the relationship between them?

- A)  $Q_M > Q_L > Q_K$
- B)  $Q_K > Q_L > Q_M$
- C)  $Q_K = Q_L > Q_M$
- D)  $Q_L = Q_M > Q_K$
- E)  $Q_M = Q_L = Q_K$

23. Bodies A, B and C with equal volumes are balanced in a homogeneous liquid as shown in the figure.

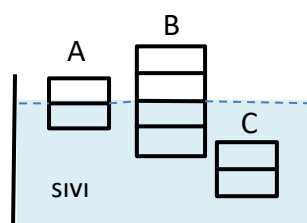

If the masses of the objects are;  $m_A$ ,  $m_B$  and  $m_C$ , respectively, what is the relationship between these masses?

- A)  $m_A < m_B < m_C$
- B)  $m_C < m_A < m_B$
- C)  $m_B < m_A = m_C$
- D)  $m_A < m_B = m_C$
- E)  $m_B = m_C < m_A$

## SCIENCE TEST

24. When a piece of ice is placed in water in a thermally insulated container at sea level. The ice mass – time graph is given below.

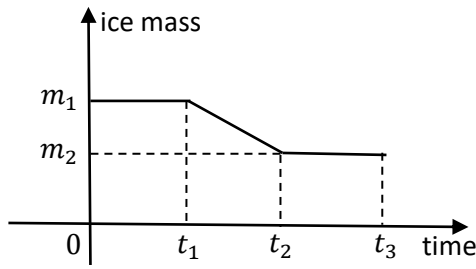

Accordingly,

- I. In  $0 - t_1$  interval, the temperature of the ice is below  $0^\circ\text{C}$ .
- II. In  $t_1 - t_2$  interval, the temperature of the ice is over  $0^\circ\text{C}$ .
- III. In  $t_2 - t_3$  interval, both the temperatures of water and ice are  $0^\circ\text{C}$ .

Which of the above statements are correct?

- A) Yalnız I.                      B) Yalnız II.  
 C) I. ve II.                      D) I. ve III.  
 E) I., II. ve III.

25. An observer is looking at the mirror from the point G, shown in the figure. Determine, which of the objects that the observer can not see.

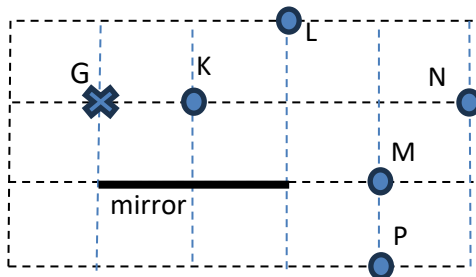

- A) K and L  
 B) K, L and N  
 C) M and P  
 D) M, N and P  
 E) K, L, M and N

26. A vehicle with a mass of 400 kg, which is climbing a ramp, passes the point K, at a velocity of  $10\text{ m/s}$ . The height of the point K from the ground is 5m, shown in the figure.

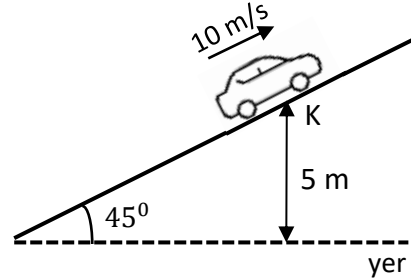

Accordingly, find the mechanical energy, in kilojoules, of the vehicle at the point K relative to the ground? ( $g = 10\text{ m/s}^2$ )

- A) 10  
 B) 20  
 C) 40  
 D) 60  
 E) 80

27. Two stationary charges  $q_1$  and  $q_2$  are placed at the points; K and L, shown in the figure. Then the  $-q$  charge is released between the points K and L and it remains at balance.

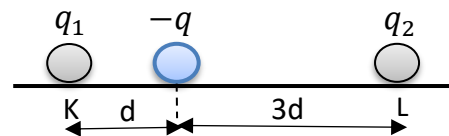

Accordingly, what is the  $\frac{q_1}{q_2}$  ratio?

- A)  $\frac{1}{9}$   
 B)  $\frac{1}{3}$   
 C) 1  
 D) 3  
 E) 9

## SCIENCE TEST

28. The masses of objects X and Y, whose surface areas  $S$  and  $2S$ , are  $2m$  and  $m$ , respectively. When the objects are placed on top of each other as shown in the figure. The pressure applied by Y to X becomes  $P_1$  and the pressure applied by X to the ground becomes  $P_2$ .

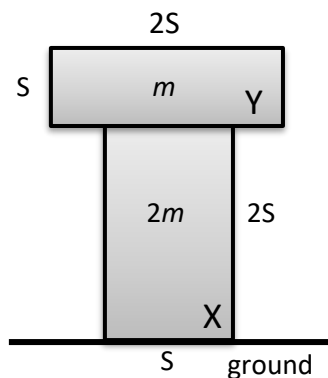

Accordingly, what is the  $\frac{P_1}{P_2}$  ratio?

- A)  $\frac{1}{3}$
- B) 1
- C) 3
- D)  $\frac{1}{2}$
- E) 4

29. A point light source and two identical balls are placed in front of a curtain shown as in the figure.

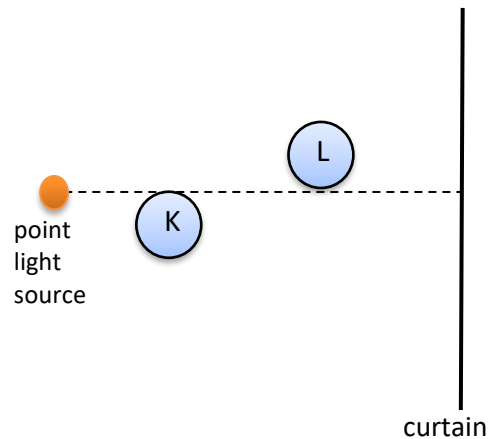

Accordingly, which of the following shadows will be seen on the curtain?

- A)
- B)
- C)
- D)
- E)

## SCIENCE TEST

30. The circuits; I., II. and III. given below, are established by  $R$  resistors. If the equivalent resistances of these circuits are  $R_1$ ,  $R_2$  and  $R_3$ , respectively, what is the relationship among these equivalent resistances?

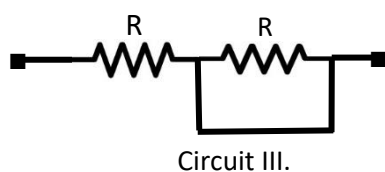
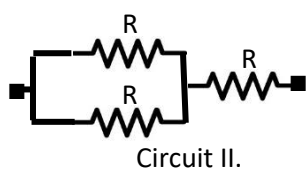
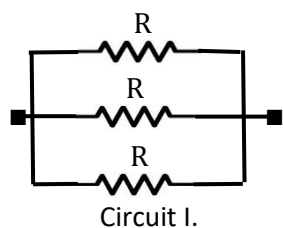

- A)  $R_1 < R_2 < R_3$   
B)  $R_1 < R_2 = R_3$   
C)  $R_2 = R_3 < R_1$   
D)  $R_1 < R_3 < R_2$   
E)  $R_3 < R_1 = R_2$

Science Test ended.



## ENGLISH LANGUAGE TEST

Find the word or expression that fits the blanks in questions 1. – 6.

1. She worked in the general store of the company as a seller and \_\_\_\_\_ cooked for its workers.

- A) already    B) hardly    **C) also**  
D) never    E) almost

2. Technology usually affects society \_\_\_\_\_ directly than science, because it solves practical problems.

- A) rather    B) far less  
C) less    **D) a lot more**  
E) by far the most

3. One of the main problems that Türkiye has been unable to solve over the years is the matter of migration from Anatolia to İstanbul. As a result of ongoing problem, İstanbul \_\_\_\_\_ overpopulated.

- A) had become    B) was becoming  
**C) has become**    D) will become  
E) had been becoming

4. Manchester City is a football club based in Manchester, founded in 1880. They \_\_\_\_\_ Premier League Cup 7 times.

- A) have won**    B) had won  
C) were won    D) are winning  
E) were winning

5. Basketball is one \_\_\_\_\_ sports in United States.

- A) the more popular    B) as popular as  
C) such a popular    D) far more popular  
**E) the most popular**

6. Alex went for a long walk \_\_\_\_\_ he was feeling very tired.

- A) therefore    B) because  
C) however    **D) although**  
E) despite

Find the word that is closest in meaning to the word/expression given in questions 7. – 8.

7. 'Convenient'

- A) capable    **B) suitable**  
C) difficult    D) pleasant  
E) correct

8. 'Get over'

- A) pass    B) leave    C) escape  
**D) recover**    E) discover

In the texts given below, find the word or expression that fits the blanks numbered 9. to 16.

The benefits of the earth's resources (9.) \_\_\_\_\_ fresh water, air, soil and trees can be reduced by using them wastefully (10.) \_\_\_\_\_ by destroying them deliberately or inadvertently. The atmosphere and oceans have a limited capacity to absorb (11.) \_\_\_\_\_ and recycle materials naturally.

9. A) as of    B) as to    C) as  
**D) such as**    E) as for

10. A) yet    B) but    **C) or**  
D) for    E) so

11. A) wasting    **B) wastes**  
C) wasted    D) to waste  
E) to be wasting

## ENGLISH LANGUAGE TEST

An atom is the smallest particle that composes a chemical element. An atom consists (12.) \_\_\_\_\_ an electron cloud (13.) \_\_\_\_\_ surrounds a dense nucleus. The nucleus contains positively charged protons and electrically neutral neutrons. (14.) \_\_\_\_\_ the surrounding cloud is made up of negatively charged electrons. When (15.) \_\_\_\_\_ protons in the nucleus equals that of electrons, the atom is electrically neutral; (16.) \_\_\_\_\_, it is an ion and has a net positive or negative charge.

12. A) for            B) at            C) on  
      D) of            E) by
13. A) that            B) what  
      C) in which        D) of which  
      E) where
14. A) Whereas        B) Until  
      C) In spite of       D) By the time  
      E) Thus
15. A) a number of     B) the number of  
      C) too many        D) so much  
      E) only a few
16. A) in addition to   B) otherwise  
      C) thanks to        D) due to  
      E) such as

Find the expression that appropriately completes the sentence in questions 17. – 19.

17. \_\_\_\_\_, before the calculator was invented.  
A) People used to be better at mental arithmetic  
B) Everything will be so different  
C) Ancient people used various tools while hunting  
D) Mathematics and tables are age old companions  
E) Tables make computing easier and faster
18. \_\_\_\_\_; finally, the doors of the stadium were opened.  
A) The crowd waited patiently for three hours  
B) Hundreds of football fans have protested violently on ground  
C) Nobody wants to wait in the queue for so long  
D) The game of football has been associated with violence  
E) The authorities will have made every effort to keep order
19. If I had known that you had such a busy schedule, \_\_\_\_\_.  
A) I will do my best to be of assistance  
B) I was the only person who knew nothing  
C) it may be easier to find a solution  
D) you can have the rest of the day off  
E) I wouldn't have asked you to help me

## ENGLISH LANGUAGE TEST

Find the sentence that is closest in meaning to the sentence given in questions 20. – 21.

- 20.** Unfortunately, she is always telling me lies about where she goes after work.
- A) Only if she tells me the truth can she go wherever she wants after work.
  - B) If only she wouldn't tell me lies about where she goes after work.**
  - C) She goes somewhere after work, but I don't exactly know how she goes.
  - D) Actually she doesn't want to go anywhere, but I have to make her go.
  - E) I don't care where she goes after work as long as she does her work properly.
- 21.** The thief had run away by the time the police arrived.
- A) The thief was able to escape after the police had arrived.
  - B) When the police came to the scene, the thief had already gone.**
  - C) The fact that the police arrived a little late was not enough for the thief to escape.
  - D) The thief failed to escape, though the police arrived a little late.
  - E) The police's late arrival prevented the thief from running away.

Find the appropriate sentence that can be inserted into the blank space in the text in questions 22. – 23. To ensure completeness of meaning.

- 22.** In 1945, at the end of World War Two, the US dropped atomic bombs on the Japanese cities of Hiroshima and Nagasaki. The bomb killed more than three million people. \_\_\_\_\_. But they suffered all through their lives from the horrible effects of radiation.
- A) They also do one nuclear test after another
  - B) That made the people of Japan angry
  - C) About three hundred thousand were left alive**
  - D) El Salvador was ruled by a military dictator at that time
  - E) America's nuclear test of 1954 had a radiation effect on Japanese fishermen
- 23.** For many years, scientists have warned that smoking tobacco is bad for our health. Yet people around the world continue to smoke. More than four million people die each year from the effects of smoking. That number is increasing. \_\_\_\_\_. Seven in ten of those will be in developing countries.
- A) Tobacco use is the leading preventable cause of death
  - B) Smoking has also been linked to heart disease, stroke and many kinds of cancer
  - C) More than forty chemicals in tobacco smoke cause cancer in humans and animals.
  - D) Women using tobacco during pregnancy will have babies with health problems.
  - E) 150 million people will die from tobacco use in the next twenty years**

## ENGLISH LANGUAGE TEST

Read the passage given below and answer questions 24. and 25. according to the passage.

In many countries in the process of industrialization, overcrowded cities present a major problem. The overpopulation of cities is mainly caused by the drift of large numbers of people from the rural areas. The only long-term solution is to make life in the rural areas more attractive, which would encourage people to stay there. This could be achieved by providing incentives for people to go and work in the villages. Moreover, facilities in the rural areas, such as transport, health and education services should be improved.

24. According to the passage, one significant outcome of industrialization has been \_\_\_\_\_.
- A) an overall increase in the population of the country.
  - B) the emergence of new cities throughout the country.
  - C) the decline of health services in cities.
  - D) a general improvement in the quality of urban life.
  - E) a massive migration from the countryside to cities.

25. The author suggests that, in order to solve the problem of overcrowding in cities, \_\_\_\_\_.
- A) health and education services in the cities have to be modernized.
  - B) the number of those migrating to the cities should be restricted.
  - C) living conditions in the countryside need to be made better and more agreeable.
  - D) measures should be taken to make the city environment more attractive.
  - E) transport facilities have to be renewed completely.

Find the expression that can complete the conversation given in question 26.

26. Fred: You promised to call me back last night but you didn't. Have you got an explanation?
- Osayi: \_\_\_\_\_.
- Fred: You are talking like an old man, Fred.
- Osayi: Age is not the only factor that affects memory. You know there are other things like exercise, nutrition and stress.
- A) I know but promise to forgive me when I explain why.
  - B) I had a terrible backache. I couldn't even stand upright.
  - C) The tablets that the doctor prescribed were no good.
  - D) People who smoke a lot have a weaker memory than those who don't.
  - E) My memory is not as good as it used to be.

## ENGLISH LANGUAGE TEST

Translate the following sentences given in questions 27. – 28. to Turkish.

27. When a scientific investigation is done the way it was done before, we expect to get a very similar result.

- A) Bilimsel bir araştırma daha önce yapıldığı gibi yapıldığında, çok benzer bir sonuç almayı beklemek yanlış olmaz.
- B) Bilimsel bir araştırmayı daha önce yapıldığı gibi yapmak, çok benzer bir sonuç almayı beklemek anlamına gelir.
- C) Bilimsel bir araştırma daha önce yapıldığı gibi yapıldığında, çok benzer bir sonuç almayı bekleriz.
- D) Bilimsel bir araştırmadan çok benzer bir sonuç almayı bekleyebilmek için, daha önce yapıldığı gibi yapmak gerekir.
- E) Çok benzer bir sonuç almayı istemiyorsak, bilimsel bir araştırmayı daha önce yapıldığı gibi yapmamaya özen göstermeliyiz.

28. Those who create technology have a different vision of future than those who must purchase their technology.

- A) Teknolojiyi yaratanların gelecek vizyonu, teknolojiyi satın alanlarınkinden çok farklıdır.
- B) Teknolojiyi yaratmak, teknolojiyi satın almak zorunda olanlarınkinden farklı bir gelecek vizyonuna sahip olmayı gerektirir.
- C) Teknoloji satın almak zorunda olanlar teknolojiyi yaratanlardan farklı bir gelecek hayali kurarlar.
- D) Yaratılan teknolojiyi satın almak için, teknolojiyi yaratanlar kadar zengin bir gelecek vizyonuna sahip olmak gerekir.
- E) Teknolojiyi yaratanlar, onların teknolojisini satın almak zorunda olanlardan farklı bir gelecek vizyonuna sahiptirler.

## ENGLISH LANGUAGE TEST

Translate the following sentences given in questions 29. – 30. to English.

29. Döviz fiyatlarının neden dalgalandığını anlamak istiyorsan, yabancı piyasaları gözlemlemen yeterli olacaktır.
- A) If you want to understand why foreign exchange rates fluctuate, it will be enough for you to observe the foreign markets
- B) Anybody who wants to understand why foreign exchange rates fluctuate should observe the foreign markets.
- C) Understanding why foreign exchange rates fluctuate requires that you always observe the foreign markets.
- D) You will understand why foreign exchange rates fluctuate when you observe the foreign markets.
- E) If you can understand why foreign exchange rates fluctuate, then it means you are observing the foreign markets.

30. Geçen gün tartıştığımız konuyu ele alan makaleyi okuyan herkes çok beğendiğini söylüyor.

- A) Everybody read the article dealing with the subject we discussed the other day, and they said they like it very much.
- B) Whoever read the article concentrating on the subject we discussed yesterday had to say they liked it very much.
- C) By reading the article dealing with the subject we discussed the other day, everybody learned why we liked it very much.
- D) Everybody who read the article dealing with the subject we discussed the other day, said they liked it very much.
- E) Not everybody who read the article about the point of view we discussed the other day, said they didn't like it very much.

English Language Test Ended